



ROTATING WAFFLE MAKER

Model number: 169118

UPC: 681131691185

Customer Assistance

1-877-207-0923 (US)

1-877-556-0973 (Canada)



Thank you for purchasing a GE small appliance.

In keeping with the GE ecomagination initiative, please consider the option to recycle the packaging material and donate the appliance you are no longer using.

ecomaginationSM

To read about GE's ecomagination commitment, visit
<http://ge.ecomagination.com>

IMPORTANT SAFEGUARDS

When using electrical appliances, basic safety precautions should always be followed to reduce the risk of fire, electric shock, and/or injury to persons including the following:

- **READ ALL INSTRUCTIONS.**
- Do not touch hot surfaces. Use handles or knobs.
- To protect against electric shock, do not place cord, plugs, or appliance in water or other liquid.
- Close supervision is necessary when toaster is used by or near children.
- Unplug from outlet when not in use and before cleaning. Allow to cool before putting on or taking off parts, and before cleaning the appliance.
- Do not operate any appliance with a damaged cord or plug or after the appliance malfunctions, or has been damaged in any manner. Call our toll-free customer service number for information on examination, repair or adjustment.
- Do not use outdoors.
- Do not let cord hang over edge of table or counter, or touch hot surfaces.
- Do not place on or near a hot gas stove or electric burner or in a heated oven.
- The use of accessory attachments not recommended or sold by the appliance manufacturer may cause fire, electric shock or injury to persons. Not recommended.
- When finished baking waffles, set the heat to the lowest setting and remove plug from wall outlet.
- Do not clean container with cleansers, steel wool pads, or other abrasive material.
- Non-skid feet must be in operating position when using waffle maker.

SAVE THESE INSTRUCTIONS!

CONSUMER SAFETY INFORMATION

This appliance is intended for household use only.

CAUTION: To ensure continued protection against risk of electric shock, connect to properly grounded outlets only.

Short Power Supply Cord Information

A short power-supply cord is provided to reduce risks resulting from becoming entangled in or tripping over a longer cord. Longer extension cords are available and may be used if care is exercised in their use. If a long extension cord is used, the marked electrical rating of the extension cord should be at least as great as the electrical rating of the appliance. The longer cord should be arranged so that it will not drape over the counter top or tabletop where it can be pulled on by children or tripped over accidentally.

The extension cord must be a grounding type 3-wire cord.

Before Using For The First Time:

Remove all packaging materials and wash all parts

See "Cleaning" section of manual.

When your Waffle Maker is new you may notice a slight smoking effect or odor. This is normal with any appliance that heats up and will not reoccur. This does not affect the safety or your appliance.

NOTE: It is recommended that you discard the first waffle made on your new baker.

PARTS

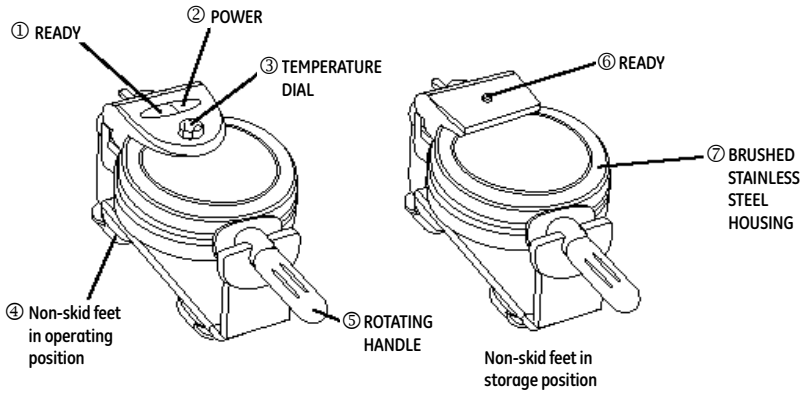

1. Ready Indicator Light
2. Power Indicator Light
3. Temperature Dial
4. Non Skid Feet
5. Rotating Handle
6. Ready indicator Light
7. Brushed Stainless Steel Housing

FEATURES

- 180° Rotating function for even cooking and easy cleaning
- Handle for easy turning
- Non Stick Cooking surface
- Brushed Stainless Steel housing
- Easy to use menu controls on top and bottom
- Indicator lights
- Temperature dial
- Non-Skid feet; pull out for stability, swing in for storage

BELGIAN WAFFLE MAKER MODEL

Model No.	Rated voltage	Rated power	Weight
169118	120V	1200W	2071g 4.5 lbs.

SET-UP INSTRUCTIONS

With unit unplugged and cool, turn unit on its side as shown in fig. Xa. Rotate one foot 90 degrees (fig. Xb) outward until it clicks into place Xc. The leg opposite will automatically rotate into place. Do the same with the other set of feet.

To adjust the feet for storage, rotate feet inward until it clicks into place.

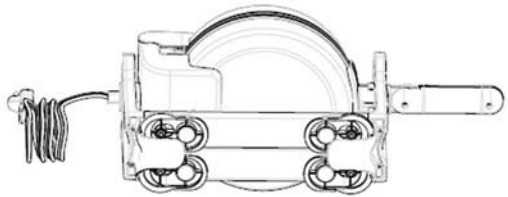
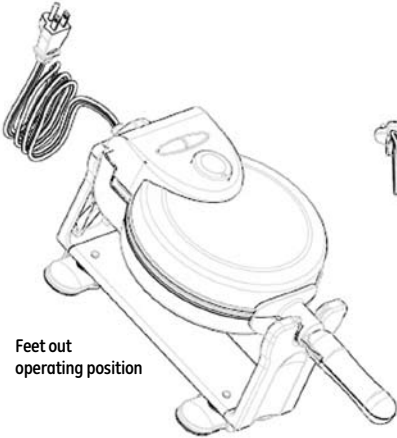

Fig. Xa

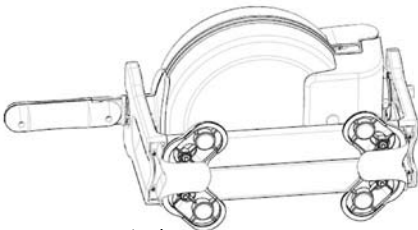

Fig. Xb

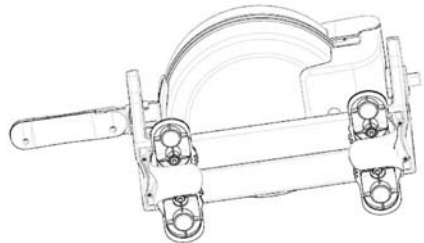

Fig. Xc

OPERATING INSTRUCTIONS

Note: Set up waffle maker by first rotating the non-skid feet 90 degrees to their standing position (see details in **SET-UP INSTRUCTIONS**). This is necessary for stability.

To use the Waffle Maker:

1. Set the browning dial to your desired setting (1-4). A lower setting produces a lighter waffle. The higher settings are darker and crispier. Different waffle batters will cook differently. With just a little trial, you will find your perfect setting for the batter you are using.
2. Close the waffle maker and plug into 110-120 VAC wall outlet. You will see the blue power light go on, indicating that the baker has power and is ready for preheating. Blue power light will remain ON until you unplug the unit.
3. Before each use, lightly coat the top and bottom waffle grids with a non-stick spray or brush with vegetable oil.
4. When the proper baking temperature is reached the green ready light will go ON. Initially it will take about 3-5 minutes to reach baking temperature. Once heated, ready times will be faster.
5. Ladle just enough batter to fill lower grid so that the peak areas of the grid are covered. If necessary, use a spatula to spread the batter into the corners of grid. At this point the green light will go OFF as the baking cycle begins.
6. Close the baker and rotate. When the green ready light illuminates, rotate the waffle maker again and open cover. Opening too soon will cause unbaked waffles to split, and make them difficult to remove.

Note: Set up waffle maker by first rotating the non-skid feet 90 degrees to their standing position (see details in **SET-UP INSTRUCTIONS**). This is necessary for stability.

7. If you want darker waffles, close the lid and continue cooking, checking every 30 seconds.
8. Remove waffles from the grid with a non-metallic utensil.
9. For best results on your next waffle, wait until green ready light illuminates and use non-stick spray before pouring batter.
10. When you are finished baking, unplug unit from wall outlet. Blue power light will go OFF. Leave baker open to allow to cool. After cooling, grids may be wiped clean with paper towels.
11. When storing, non-skid feet may be rotated inward to save room.

Instructions on how to lock the unit:

Turn the waffle maker 180 degrees clockwise until the upper housing (the side with the control dial) is facing up. When the unit is in this position, you can open the top cover. Close it and turn it back 180 degrees counter-clockwise, until the upper housing is facing down. When the unit is in this position, the waffle maker is locked and cannot be flipped open.

CLEANING

CAUTION: Be sure to unplug this appliance before cleaning. To protect against electrical shock, do not immerse cord, plug or unit in water or other liquids. After each use, always make sure plug is first removed from wall outlet.

1. After cooling any excess crumbs or oils can be wiped away with a paper towel. There is no need to disassemble appliance for cleaning.
2. Do not place the unit in the dishwasher
3. Do not use metal utensils that can damage the non-stick cooking surface. Use only wood or plastic utensils on the cooking surface.
4. Wipe the top and bottom housings with a soft cloth. A little metal polish suitable for stainless steel may be occasionally used on top housing. Do not use any abrasive scouring pads or steel wool, as this will damage the housing finishing.

CUSTOMER ASSISTANCE

For faster service, please have the model number and product name ready for the operator to assist you. This number can be found on the bottom of your appliance and on the front page of this manual.

Model Number: _____ **Product Name:** _____

Customer Assistance Number 1-877-207-0923 (U.S.) or 1-877-556-0973 (Canada)

Keep these numbers for future reference!

For more information, please visit us at www.gehousewares.com

TWO-YEAR LIMITED WARRANTY

What does your warranty cover?

- Any defect in material or workmanship.

For how long after the original purchase?

- Two years.

What will we do?

- Provide you with a new one.
- For those items still under warranty but no longer available, WAL-MART reserves the right to replace with a similar GE branded product of equal or greater value.

How do you make a warranty claim?

- Save your receipt.
- Properly pack your unit. We recommend using the original carton and packing materials.
- Return the product to your nearest WAL-MART store or call Customer Assistance at 1-877-207-0923 (U.S.) or 1-877-556-0973 (Canada).

What does your warranty not cover?

- Parts subject to wear, including, without limitation, glass parts, glass containers, cutter/strainer, blades, seals, gaskets, clutches, motor brushes, and/or agitators, etc.
- Commercial use or any other use not found in printed directions.
- Damage from misuse, abuse, or neglect, including failure to clean product regularly in accordance with manufacturer's instructions.

How does state law relate to this warranty?

- This warranty gives you specific legal rights, and you may also have other rights which vary from state to state or province to province.
- This warranty is in lieu of any other warranty or condition, whether express or implied, written or oral, including, without limitation, any statutory warranty or condition of merchantability or fitness for a particular purpose.
- WAL-MART, GE and the product manufacturer expressly disclaim all responsibility for special, incidental and consequential damages or losses caused by use of this appliance. Any liability is expressly limited to an amount equal to the purchase price paid whether a claim, however instituted, is based on contract, indemnity, warranty, tort (including negligence), strict liability, or otherwise. Some states or provinces do not allow this exclusion or limitation of incidental or consequential losses so the foregoing disclaimer may not apply to you.

What if you encounter a problem with this product while using it outside the country of purchase?

- The warranty is valid only in the country of purchase and you follow the warranty claim procedure as noted.



is a trademark of General Electric Company and is used under the license by Wal-Mart Stores Inc., Bentonville, AR 72716

Marketed in Canada by:

Wal-Mart Canada Corp.
1940 Argentia Road, Mississauga, Ontario L5N1P9